



**SUBARU**

**MODEL EX21/KX21**

**PARTS CATALPG**

**Spec.No.EX210KS8030 (KX21)  
EX210D80040 (EX21)**

**201406 Vol.3**

<b>1. CRANK CASE</b>	<b>... 1</b>
<b>2. CRANKSHAFT PISTON</b>	<b>... 2</b>
<b>3. INTAKE EXHAUST</b>	<b>... 3</b>
<b>4. INTAKE EXHAUST KX</b>	<b>... 4</b>
<b>INTAKE EXHAUST EX</b>	<b>... 5</b>
<b>5. COOLING STARTING</b>	<b>... 6</b>
<b>6. Fuel lubricant KX</b>	<b>... 7</b>
<b>Fuel lubricant EX</b>	<b>... 8</b>
<b>7. ELECTRIC DEVICE</b>	<b>... 9</b>
<b>ELECTRIC DEVICE</b>	<b>... 10</b>
<b>8. Changed from EX to KX</b>	<b>... 11</b>



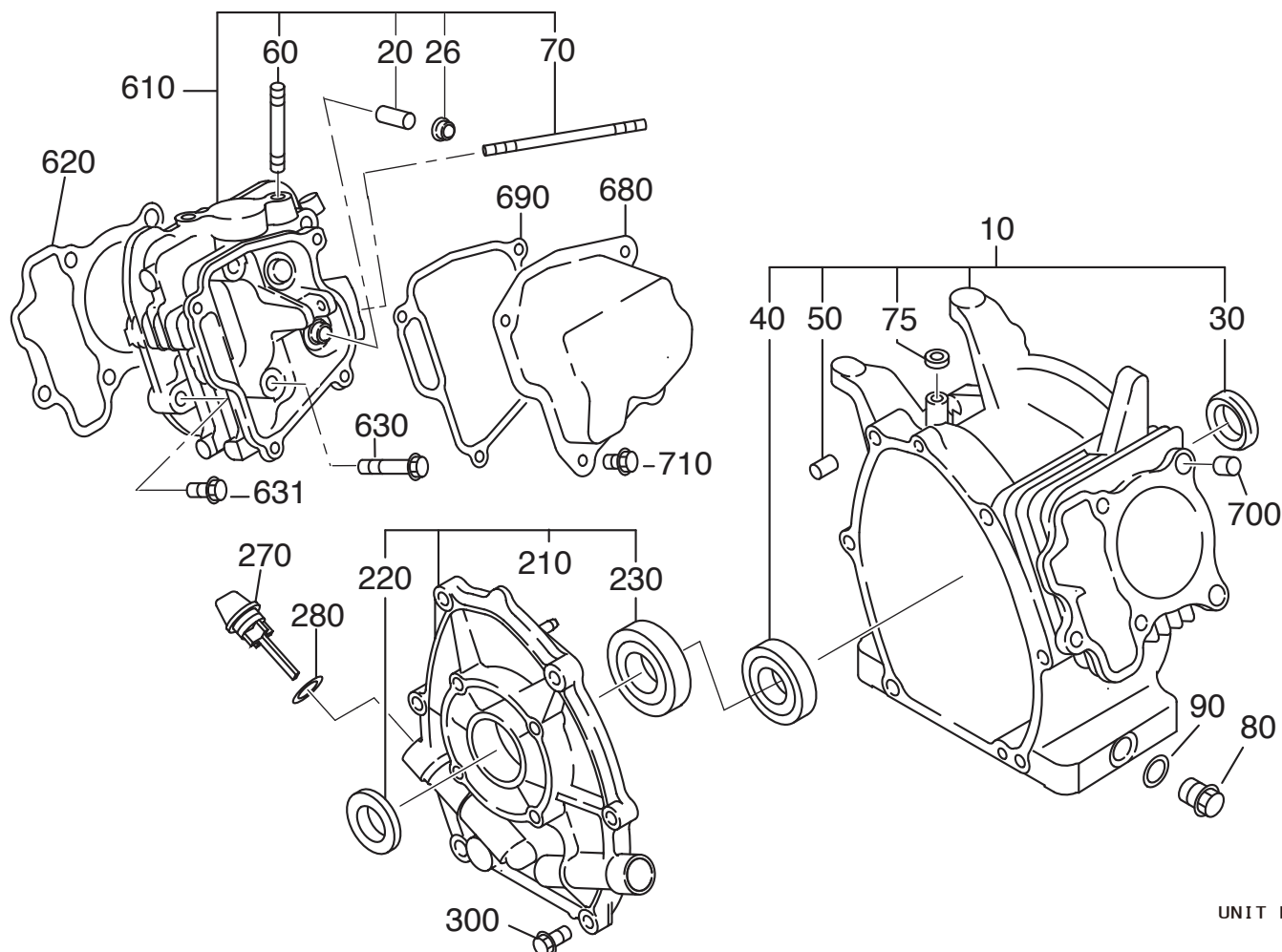

UNIT P

## 1. CRANK CASE

## 960-GASKET SET

REF.	PART NUMBER	PART NAME	QTY	REMARKS	EX-KX	WEIGHT	UNIYP(税込)
10	278-10101-41	CRANK CASE CP	1		EX-KX	3,200.0 g	31,000
20	237-14202-03	VALVE GUIDE	2	5.5DX9.5DX27L	EX-KX	9.0 g	1,300
26	277-16010-01	STEM SEAL	1	5.5DX9.5DX15DX7.8B	EX-KX	1.0 g	240
30	044-02502-00	OIL SEAL	1	25DX38DX7B	EX-KX	4.0 g	500
40	060-02800-21	BALL BEARING	1	28DX58DX16B	EX-KX	150.0 g	1,050
50	277-15011-03	PIPE KNOCK	2	10.3DX8.5DX14L	EX-KX	2.0 g	50
60	010-50802-50	STUD	2	M8X1.25X25L	EX-KX	8.0 g	90
70	010-50603-51	EX STUD	2	M6X1.0X98L	EX	g	180
	010-50604-10	KX STUD	2	M6X1.0X107L	KX	17.0 g	180
75	044-00600-20	OIL SEAL	1	6DX10DX2.5B	EX-KX	- g	260
80	040-11400-30	PLUG	2	M14X1.5X20DX12L	EX-KX	24.0 g	140
90	021-11400-20	GASKET	2	14.1DX19DX2.3T	EX-KX	1.0 g	40
210	277-11002-21	MAIN BEARING COVER C	1	FLANGE 4-5/16-24UNF	EX-KX	750.0 g	7,400
220	044-02502-10	OIL SEAL	1	25DX41.25DX6B	EX-KX	4.0 g	540
230	060-02501-40	BALL BEARING	1	25DX52DX15B	EX-KX	127.1 g	660
270	277-63601-23	OIL GAUGE	2	M18X1.5L=70+18	EX-KX	0.7 g	270
280	021-31600-20	GASKET	2	16DX23DX1.2T RUBBER	EX-KX	- g	40
300	001-04083-50	FLANGE BOLT	6	M8X1.25X16DX35L	EX-KX	19.0 g	90
610	278-13010-11	KX CYLINDER HEAD CP	1		KX	967.9 g	17,000
	278-13010-11	KX CYLINDER HEAD CP	1	VALVE GUIDE対策加工品	KX	968.0 g	25,000
	278-13001-11	EX CYLINDER HEAD CP	1		EX	900.0 g	17,000
620	277-15001-33	GASKET(HEAD)	1	T=0.2	EX-KX	6.9 g	500
630	011-00802-40	FLANGE BOLT	4	M8X1.25X16DX68L	EX-KX	27.8 g	180
631	011-00803-10	FLANGE BOLT	1	M8X1.25X16DX33L	EX-KX	20.0 g	100
680	277-15503-01	ROCKER COVER CP	1		EX-KX	300.0 g	1,800
690	277-16001-13	GASKET(ROCKER COVER)	1	T=0.5	EX-KX	1.8 g	240
700	277-15011-03	PIPE KNOCK	2	10.3DX8.5DX14L	EX-KX	2.0 g	50
710	011-00600-20	FLANGE BOLT	4	M6X1.0X14DX12L	EX-KX	6.0 g	90
960	277-99001-37	GASKET SET	1		EX-KX	35.2 g	950

## 2. CRANKSHAFT, PISTON

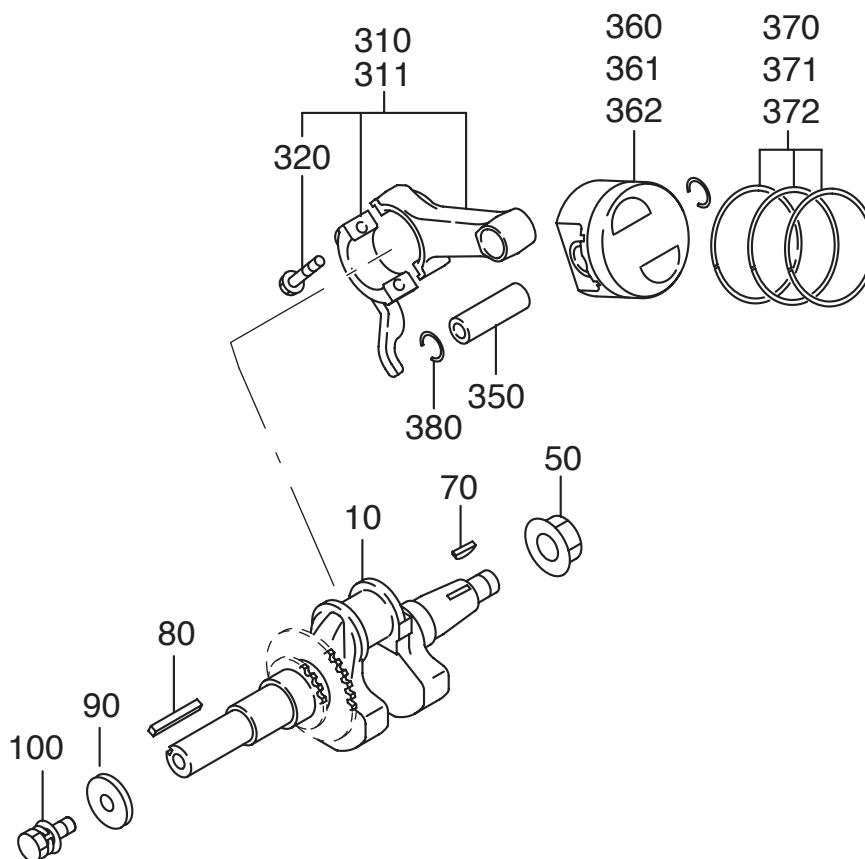

## 2. CRANKSHAFT, PISTON

REF.	PART NUMBER	PART NAME	QTY	REMARKS		WEIGHT	UNIYP (税込)
10	278-20901-61	CRANKSHAFT CP Φ19,05	1	L=260 DU 19.05DX58.5	EX-KX	1,850.0 g	17,000
	278-20201-51	CRANKSHAFT CP Φ20.00	1	L=260 DU 20.0 DX58.5	EX-KX	1,850.0 g	17,000
50	018-01400-20	FLANGE NUT	1	M14X1.5X28DX12H	EX-KX	20.0 g	130
70	032-30300-10	WOODRUFF KEY	1	3BX6HX16D	EX-KX	2.0 g	160
80	206-26001-13	KEY Φ19.05	1	4.75BX4.7HX35L	EX-KX	6.0 g	280
	032-00501-50	KEY Φ20.00	1	5.0BX4.97HX35L	EX-KX	6.0 g	280
90	020-00801-40	WASHER	1	8.5DX28DX4.5T	EX-KX	18.0 g	140
100	011-00803-80	FLANGE BOLT Ø19.05	1	5/16X16DX25L DU	EX-KX	15.5 g	1,300
	011-00802-50	FLANGE BOLT Ø20.00	1	M8X1.25X16DX25L	EX-KX	12.0 g	100
310	278-22501-10	CONNECTING ROD AY	1	91.3CDX25B 30D-16D	EX-KX	125.0 g	5,200
311	278-22502-00	CONNECTING ROD AY	1	0.25 UNDER SIZE	EX-KX	140.0 g	5,400
320	277-23001-03	CONNECTING ROD BOLT	2	M6X1.0X13DX33L	EX-KX	8.0 g	170
350	277-23301-13	PISTON PIN	1	16DX11DX48.5L	EX-KX	40.0 g	500
360	277-23401-J3	PISTON	1	STD (67DX40H)	EX-KX	150.0 g	2,250
361	277-23403-J3	PISTON	1	0,25 O.S.(67DX40H)	EX-KX	150.0 g	2,350
362	277-23404-J3	PISTON	1	0,50 O.S.(67DX40H)	EX-KX	150.0 g	2,350
370	277-23511-37	PISTON RING SET	1	STD(67D) OIL EXPANDE	EX-KX	20.0 g	2,650
	277-	Low friction RING SET	1	STD OIL EXPANDE	EX-KX	16.0 g	4,300
371	277-23512-17	PISTON RING SET	1	0.25 O.S. OIL EXPAND	EX-KX	20.0 g	2,700
	277-	Low friction RING SET	1	0.25 O.S. OIL EXPAND	EX-KX	16.0 g	4,400
372	277-23513-17	PISTON RING SET	1	0.50 O.S. OIL EXPAND	EX-KX	20.0 g	2,700
	277-	Low friction RING SET	1	0.50 O.S. OIL EXPAND	EX-KX	16.0 g	4,400
380	056-51600-10	PISTON PIN CLIP	2	17.1DX1.4D	EX-KX	1.0 g	60

### 3 INTAKE EXHAUST

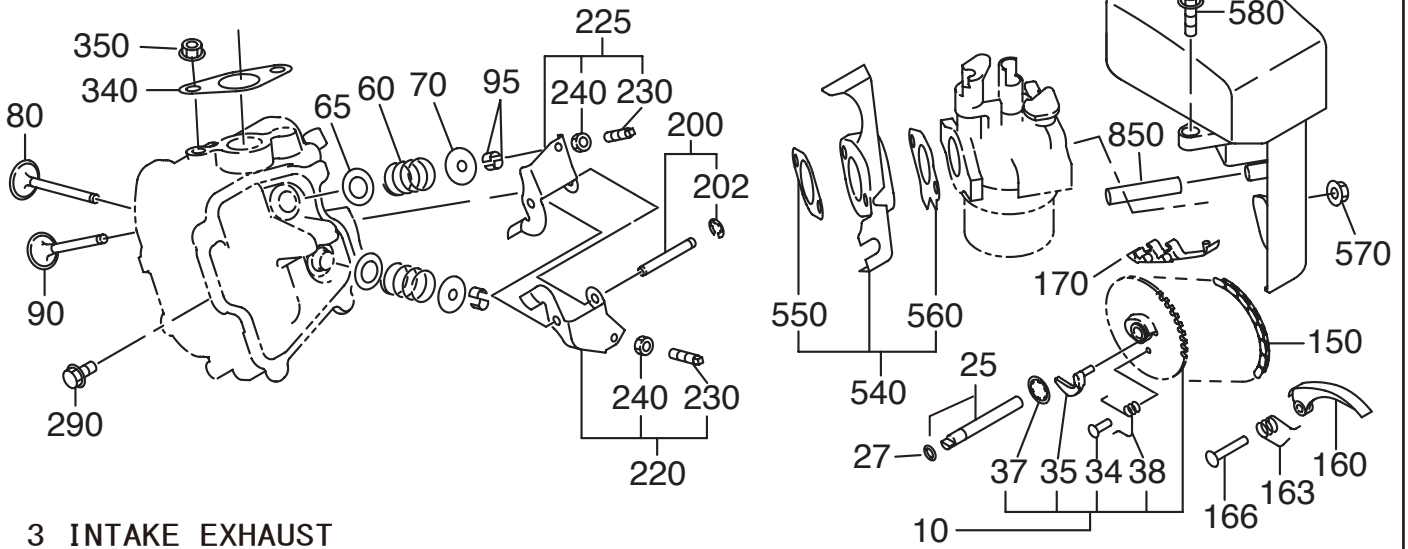

### 3 INTAKE EXHAUST

REF.	PART NUMBER	PART NAME	QTY	REMARKS		WEIGHT	UNIY P (税込)
10	278-31602-21	KX CAM SHAFT CP	1	85D X 2.9BN=40	KX	186.4 g	6,100
	277-31601-51	EX CAM SHAFT CP	1	85DX2.9B N=40	EX	170.0 g	6,200
25	277-35101-03	PIN(Cam shaft) assy27	1	9DX78.5L	EX-KX	30.0 g	640
27	024-00600-10	CAM PIN O RING	1	5.8DX-.6D	EX-KX	g	130
34	277-38601-03	PIN(SPRING)	1	4DX8DX9L	EX-KX	1.0 g	50
35	277-36401-03	RELEASE LEVER	1		EX-KX	6.0 g	780
37	278-38801-03	CAM SHAFT CLIP	1		EX-KX	g	1,620
38	277-38702-03	RETURN SPRING	1	5.1DX0.6DX4.4L N=7	EX-KX	1.0 g	110
60	279-33601-03	VALVE SPRING	2	19.2DX2.3DX27.4L	EX-KX	10.0 g	170
65	278-38802-03	SPACER SPRING	2		KX	1.6 g	100
70	269-33701-03	SPRING RETAINER	2		EX-KX	8.0 g	270
80	279-33401-H3	KX INTAKE VALVE	1	28,5DX5.5DX67.8L	KX	26.0 g	1,100
	277-33401-H3	EX INTAKE VALVE	1	25.5DX5.5DX68.1L	EX	22.0 g	1,000
90	279-33501-H3	KX EXHAUST VALVE	1	26,5DX5.5DX67.8L	KX	27.0 g	1,700
	277-33501-H3	EX EXHAUST VALVE	1	23.5DX5.5DX68.1L	EX	23.0 g	1,600
95	132-10KAO-31	COLLET-VALVE	4		EX-KX	1.0 g	90
150	278-35601-11	TIMING CHAIN CP	1	92 LINK	EX-KX	90.0 g	1,700
160	277-36911-03	TENTIONER	1		EX-KX	1.0 g	220
163	277-37101-03	SPRING(TENTIONER)	1	10DX1.8DX14L N=4.5	EX-KX	4.0 g	160
166	277-36902-03	PIN(TENTIONER)	1	6DX13DX34L	EX-KX	9.0 g	170
170	277-36913-13	CHAIN GUIDE	1		EX-KX	g	190
200	277-35004-01	PIN(ROCKER) CP	1	6DX46L	EX-KX	10.4 g	200
		PIN(ROCKER) CP (対策品)	1		EX-KX		1,620
202	003-13050-00	PIN CLIP	1	5DX11DX0.6T	EX-KX	1.0 g	20
220	277-36201-00	ROCKER ARM(IN) AY	1		EX-KX	50.0 g	1,500
225	277-36202-00	ROCKER ARM(EX) AY	1		EX-KX	50.0 g	1,400
290	011-00600-20	FLANGE BOLT	1	M6X1.0X14DX12L	EX-KX	6.0 g	90
340	277-35201-13	GASKET(MUFFLER)	2	T=..2 26D 9DX58P	EX-KX	2.0 g	130
350	980-20082-80	FLANGE NUT	1	M8X1.25X17DX7.5H	EX-KX	5.0 g	160
540	279-32905-HO	KX INSULATOR AY	1		KX	57.0 g	1,000
	277-32903-H1	EX INSULATOR AY	1	T=0.5	EX	41.7 g	900
550	279-35903-J3	GASKET2(Insulator-Emgine)	1		KX	g	60
	277-35903-J3	EX21用 GASKET2	1	T=0.5	EX	g	60
560	279-35902-J3	GASKET1(Insulator-Caub)	1		KX	1.0 g	80
	277-35902-J3	EX21用 GASKET1	1		EX	1.0 g	80
	267-35901-13	EH41用 GASKET1	2		KX	1.0 g	80
570	002-38060-00	FLANGE NUT	1	M6X1.0X13DX6H	EX-KX	4.0 g	60
580	011-00600-50	FLANGE BOLT	1	M6X1.0X13DX20L	EX-KX	7.0 g	80
850	085-10800-00	RUBBER PIPE		8DX11DX1000L	EX-KX	59.9 g	780

### 3 INTAKE EXHAUST

## KX21 DUAL ELEMENT

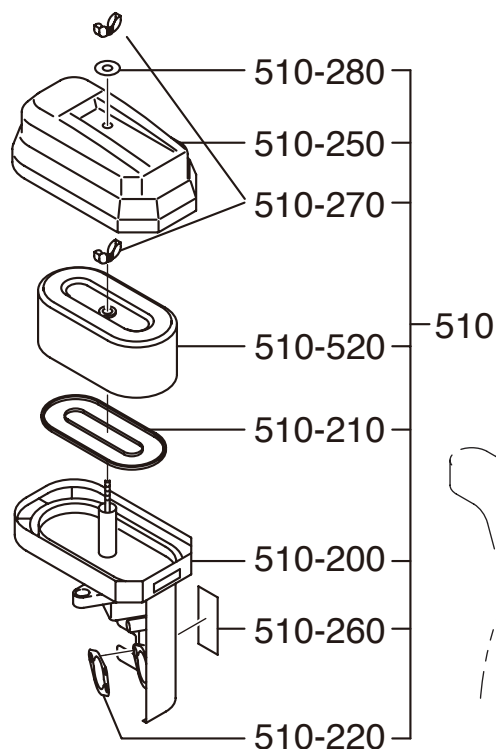

### 4 GOVERNOR OPERATION

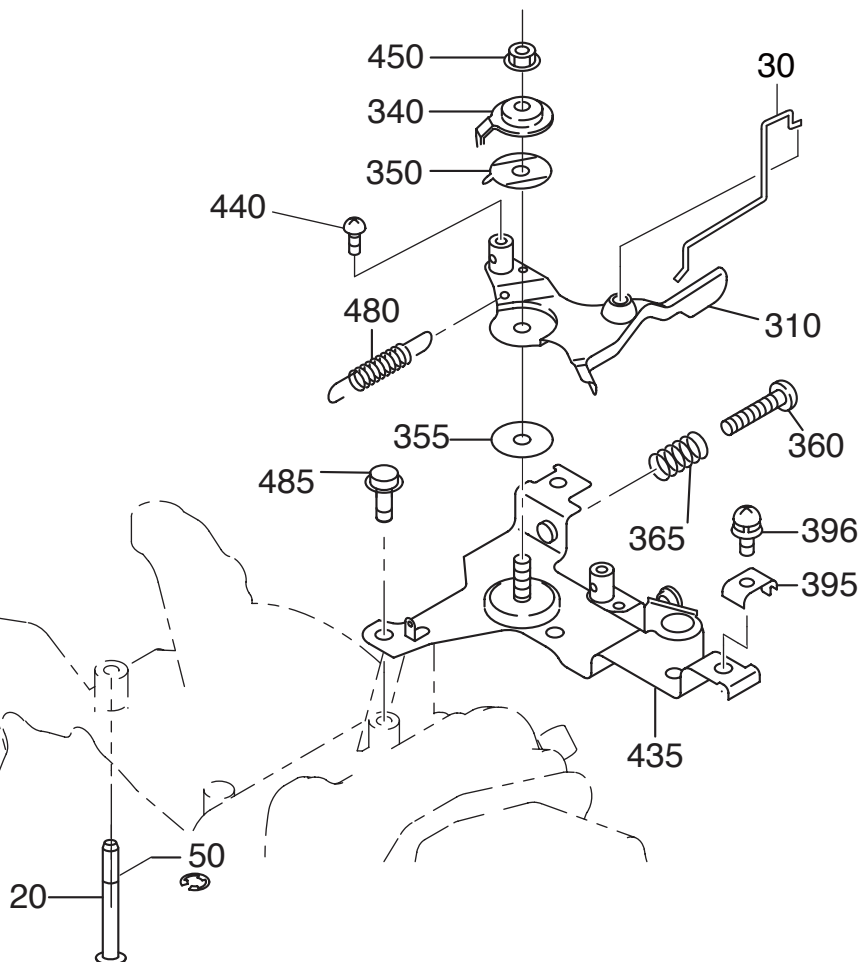

### 3 INTAKE EXHAUST

REF.	PART NUMBER	PART NAME	QTY	REMARKS	CODE NO.	WEIGHT	UNIYP (税込)
510	279-32615-60	AIR CLEANER AY	1	DUAL	-	657.2 g	7,000
-200	279-32634-28	ELBOW COMP.AIR/C	1			280.0 g	2,400
-210	279-32720-08	PACKING	1		-	6.0 g	380
-220	279-32650-18	GASKET	1		-	1.8 g	400
-250	279-32643-18	COVER	1			150.0 g	1,700
-260	279-32730-08	LABEL	1		-	g	110
-270	279-32740-08	NUT	1		-	4.0 g	180
-520	279-32607-17	ELEMENT SET	1	DUAL	-	196.0 g	3,300

### 4 GOVERNOR OPERATION

20	277-48601-03	PIN(BLIND)	1	6DX44L	-	10.0 g	190
30	277-42703-11	DIRECT ROD CP	1		-	4.0 g	340
50	003-13050-00	CLIP	1	5DX11DX0.6T	-	1.0 g	30
310	277-43303-01	SPEED CONT.LEVER CP	1	W/SWIVEL	-	60.0 g	580
340	277-43502-03	STOP PALET	1		-	9.0 g	240
350	277-44501-03	WASHER	1		-	1.0 g	60
355	021-70600-70	FRICTION WASHER	1	6.5DX24DX0.8T NYLON	-	g	50
360	004-31062-50	SCREW	1	M6X1.0X25L	-	5.0 g	30
365	237-45004-23	SPRING (ADJUST)	1	6.9DX0.9DX20L N=7	-	1.0 g	50
395	277-43902-03	CLAMP	1		-	g	220
396	013-10500-30	SCREW AND WASHER AY	1	M5X0.8X20L W/W,SW	-	4.2 g	50
435	277-46002-02	SPEED CONT.BRKT.UN	1		-	110.0 g	620
440	004-31040-80	SCREW	1	M4X0.7X8L	-	1.0 g	30
450	002-35060-00	SELF LOCK NUT	1	M6X1.0X6.8H	-	3.0 g	80
480	277-45103-03	RETURN SPRING	1	7DX0.7DX28L N=15	-	1.1 g	350
485	011-00600-20	FLANGE BOLT	2	M6X1.0X14DX12L	-	6.0 g	90

### 3 INTAKE EXHAUST

## EX21 DUAL ELEMENT

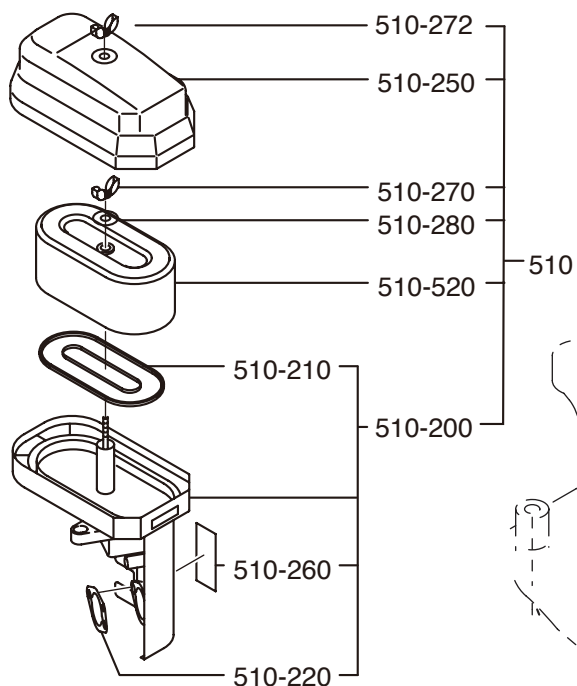

### 4 GOVERNOR OPERATION

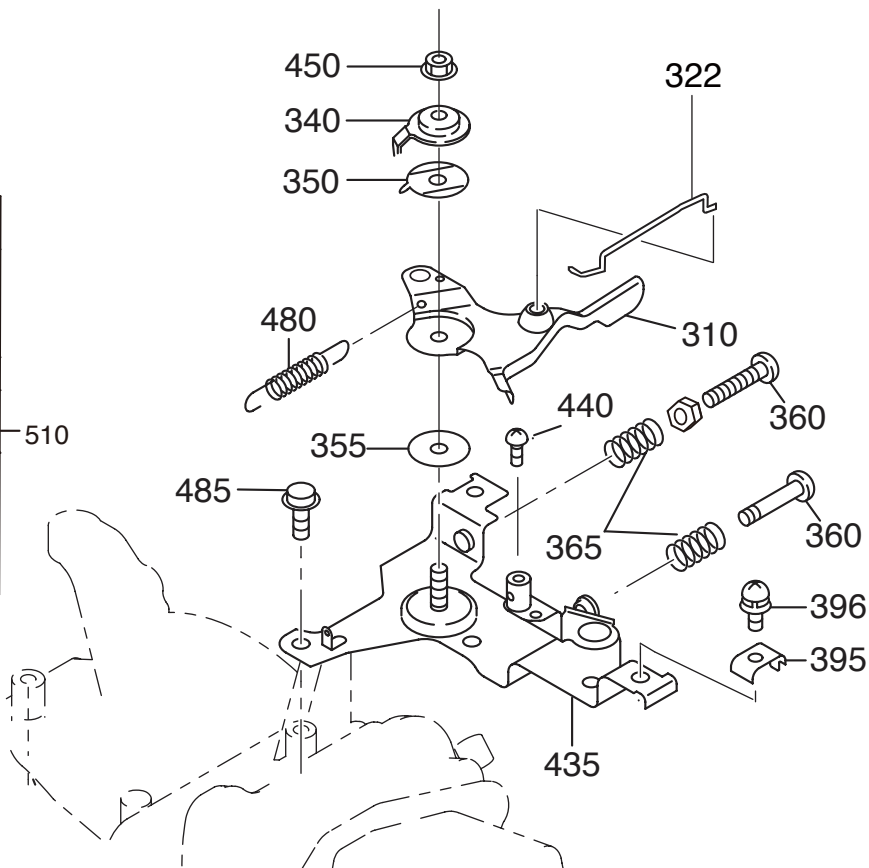

### 3 INTAKE EXHAUST

REF.	PART NUMBER	PART NAME	QTY	REMARKS		WEIGHT	UNIYP (税込)
510	277-32615-20	AIR CLEANER AY	1	DUAL	EX	350.0 g	6,000
-200	277-32630-18	ELBOW COMP.AIR/C	1		EX	150.0 g	2,300
-210	277-32610-08	PACKING	1		EX	20.0 g	530
-220	277-32604-08	GASKET	1		EX	1.0 g	260
-250	277-32640-08	COVER	1		EX	90.0 g	1,700
-260	277-32609-08	LABEL	1		EX	g	110
-270	277-32741-18	WING NUT	1		EX	4.0 g	250
-272	277-32607-08	WING NUT	1		EX	3.4 g	160
-280	277-32608-08	WSAHER	1		EX	1.0 g	110
-520	277-32611-07	ELEMENT SET	1	DUAL	EX	196.0 g	3,100

### 4 GOVERNOR OPERATION

310	277-43303-01	SPEED CONT.LEVER CP	1	W/SWIVEL	-	60.0 g	580
322	277-43701-01	LINK ROD	1		-	2.0 g	130
340	277-43502-03	STOP PALET	1		-	9.0 g	240
350	277-44501-03	WASHER	1		-	1.0 g	60
355	021-70600-70	FRICITION WASHER	1	6.5DX24DX0.8T NYLON	-	g	50
360	004-31062-50	SCREW	1	M6X1.0X25L	-	5.0 g	30
365	237-45004-23	SPRING (ADJUST)	1	6.9DX0.9DX20L N=7	-	1.0 g	50
395	277-43902-03	CLAMP	1		-	g	220
396	013-10500-60	SCREW AND WASHER AY	1	M5X0.8X20L W/W,SW	-	4.2 g	30
435	277-46002-02	SPEED CONT.BRKT.UN	1		-	110.0 g	610
440	004-31040-80	SCREW	1	M4X0.7X8L	-	1.0 g	30
450	002-35060-00	SELF LOCK NUT	1	M6X1.0X6.8H	-	3.0 g	80
480	277-45103-03	RETURN SPRING	1	7DX0.7DX28L N=15	-	1.1 g	340
485	011-00600-20	FLANGE BOLT	2	M6X1.0X14DX12L	-	6.0 g	90

5 COOLING STARTING

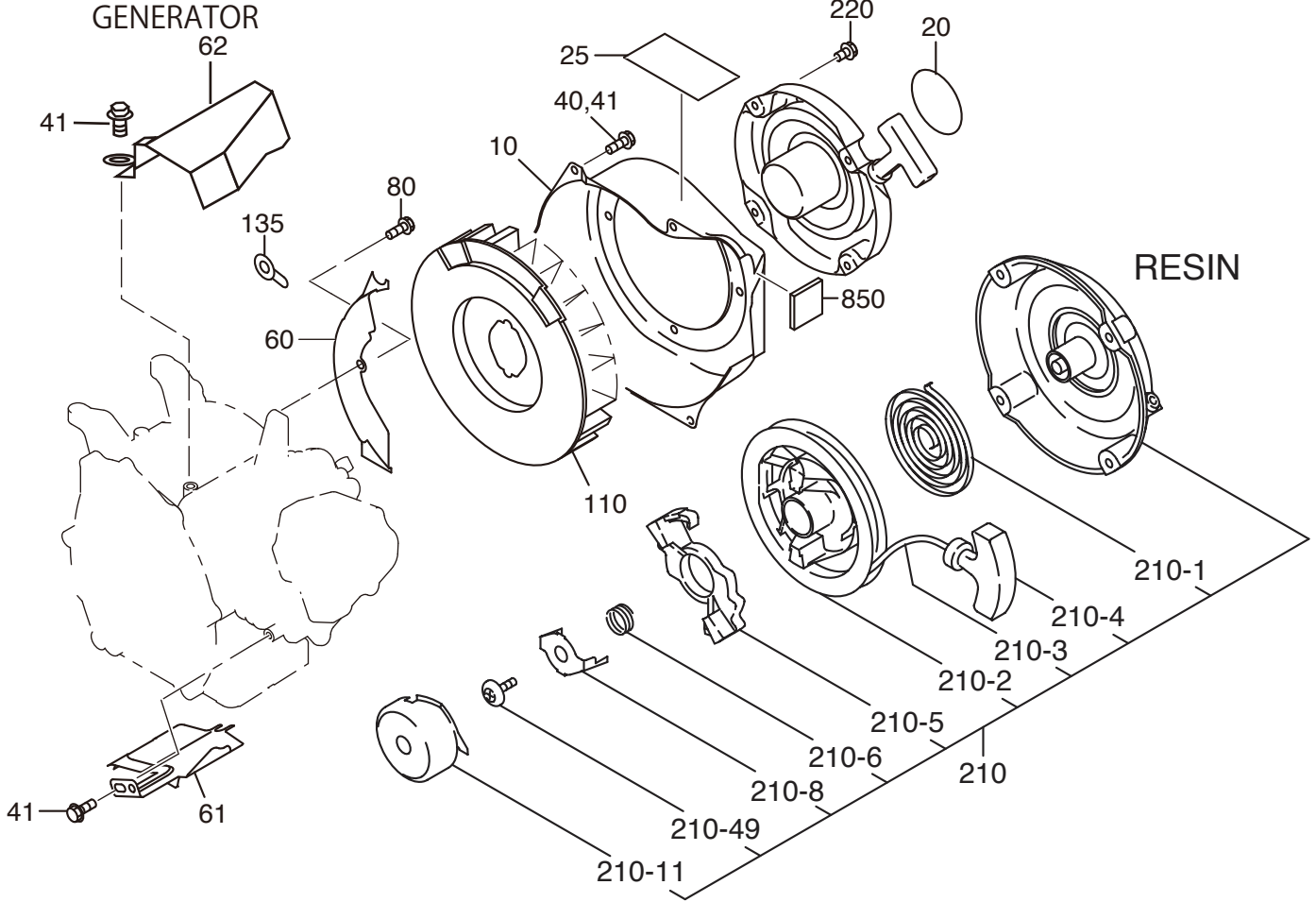

5 COOLING STARTING

REF.	PART NUMBER	PART NAME	QTY	REMARKS		WEIGHT	UNIYP ( 税別 )
10	278-51282-01	BLOWER HOUSING CP	1	BLACK	KX	530.0 g	3,950
	278-51202-01	BLOWER HOUSING CP	1	BLACK	EX	450.0 g	3,950
20	073-20054-70	LABEL (TRADE MARK)	1	60D		0.7 g	200
25	073-20049-80	LABEL(CAUTION)	1	38X80 JAPAN		g	240
40	011-00600-30	FLANGE BOLT	4	M6X1.0X14DX14L		7.0 g	80
41	011-00600-20	FLANGE BOLT	1	M6X1.0X14DX12L		6.0 g	90
60	277-52712-03	BAFFLE 1(CASE)	1			15.0 g	600
61	277-52702-03	BAFFLE 2(HEAD)	1			90.0 g	1,200
62	278-52701-03	BAFFLE 3	1		EX	50.0 g	550
80	001-04061-60	FLANGE BOLT				10.0 g	50
110	278-54101-03	COOLING BLOWER	1			100.0 g	1,300
135	277-75501-03	CLAMP(SEL)	1			g	100
220	013-00602-81	BOLT AND WASHER AY	4	M6X1.0X14L W/SW		5.4 g	40
850	277-59606-03	SPONGE 6	1				730

210	278-50301-00	RECOIL STARTER AY	1	160PD RESIN	-	410.0 g	8,050
- 1	226-50716-08	SPIRAL SPRING	1		-	50.0 g	1,900
- 2	277-50121-08	REEL	1		-	70.0 g	2,400
- 3	277-50110-08	STARTER ROPE	1		-	15.0 g	880
- 4	281-50300-08	STARTER KNOB	1		-	14.0 g	500
- 5	281-50325-08	RATCHET	1		-	20.0 g	400
- 6	281-50330-08	FRICTION SPRING	1		-	10.0 g	340
- 8	281-50340-08	FEICTION PLATE	1		-	10.0 g	340
- 11	278-50146-08	STARTER PULLEY	1		-	110.0 g	1,600
- 49	281-50351-08	CENTER SCREW	1		-	10.0 g	340

# 6 FUEL LUBRICANT KX-21 ENGINE

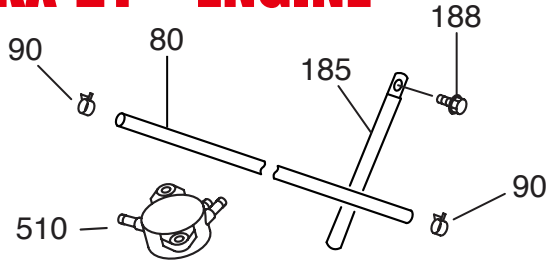

MAIN JET

税込

	PART NUMBER	PART NAME		UNIT P
210-22	226-62412-08	#80.0		920
210-22	277-62402-08	#81.3		920
210-22	278-62400-08	#82.5		920
210-22	277-62405-08	#83.8	EX/KX 標準	920
210-22	277-62403-08	#85.0		920
210-22	277-62406-08	#86.3		920
210-22	267-62408-08	#88.8		920
210-22	267-62409-08	#90.0		920
210-22	254-62402-08	#91.3		920
210-22	266-62402-08	#92.5		920
210-22	267-62404-08	#93.8		1,000
210-22	246-62403-08	#95.0		920
210-22	267-62410-08	#96.3		920
210-22	254-62403-08	#97.5		920
210-22	254-62401-08	#98.8		920
210-22	267-62402-08	#100.0	EH41標準	920
210-22	254-62404-08	#101.3		920
210-22	267-62401-08	#102.5		920
210-22	254-62406-08	#103.8		920

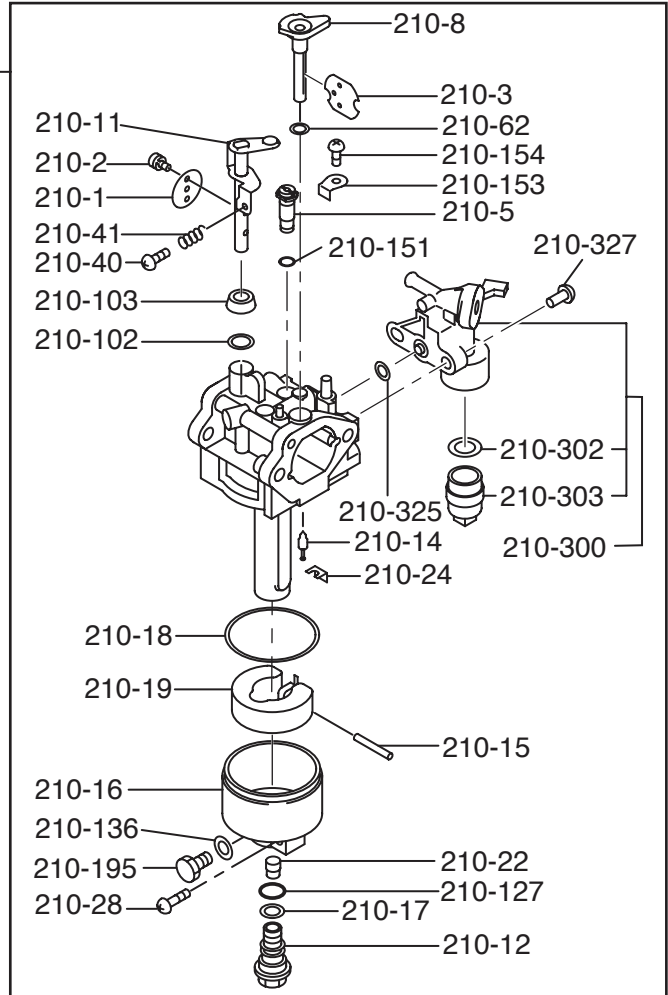

## 6 FUEL LUBRICANT

REF.	PART NUMBER	PART NAME	QTY	REMARKS	WEIGHT	UNIT P
80	085-10612-60	RUBBER PIPE	1	6DX11DX300L	g	1,400
90	056-11000-30	HOSE CLAMP	2	10DX8BX1T	1.0 g	70
185	056-60002-50	CLAMP	1	6.5DX10BX95LXO.6T	4.0 g	140
188	011-00600-20	FLANGE BOLT	1	M6X1.0X14DX12L	6.0 g	90
224	277-43801-01	CHOKE LFVER CP	1		5.0 g	360
510	33K-62201-00	FUEL PUMP CP	1		50.0 g	2,900
210	278-62351-00	CARBURETOR AY	1		383.3 g	9,000

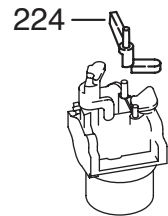

税込

REF.	PART NUMBER	PART NAME	QTY	UNIT P	REF.	PART NUMBER	PART NAME	QTY	UNIT P
210-1	279-62536-08	THROTTLE VALVE	1	2,000	- 40	106-62556-08	SCREW	1	80
- 2	209-62351-08	SCREW	2	70	- 41	283-62357-08	SPRING	1	350
- 3	279-62527-08	CHOKE VALVE	1	360	- 62	236-62680 08	SEAL	1	310
- 5	279-62421-08	PILOT JET #40	1	900	- 102	246-62390-08	SEAL	1	180
- 8	279-62522-08	CHOKE LEVEL	1	650	- 103	279-62551-08	RING	1	360
- 11	279-62533-08	THROTTLE SHAFT-A	1	2100	- 127	242-62313-08	O-RING	1	100
- 12	278-62451-08	JET HOLDER	1	1,300	- 136	209-62346-08	WASHER	1	50
- 14	224-62305-08	NEEDLE VALVE	1	2,200	- 151	106-62348-08	O-RING	1	130
- 15	214-62515-08	PIN	1	220	- 153	279-62360-08	PLATE	1	360
- 16	278-62505-08	FLOAT BODY-A	1	1,800	- 154	279-62351-08	SCREW	1	220
- 17	248-62451-08	WASHER	1	80	- 195	278-62450-08	BOLT	1	530
- 18	206-62540-08	PACKING	1	300	- 300	279-62103-10	COCK BODY-A	1	1,100
- 19	234-62506-08	FLOT-A	1	1,800	- 302	277-62110-18	PACKING	1	150
- 22	277-62405-08	MAIN JET #83.8	1	920	- 303	277-62100-18	CUP	1	290
- 24	226-62701-18	CLIP	1	330	- 325	277-62552-08	O-RING	1	330
- 28	214-62454-08	SCREW	1	540	- 327	165-62377-08	SCREW	2	70



## 6 FUEL LUBRICANT

# EX-21 ENGINE

KX21 エンジンと同じ部品もありますが,ほとんどが EX21 専用です。  
メインジェットは、KX21 と共通です。

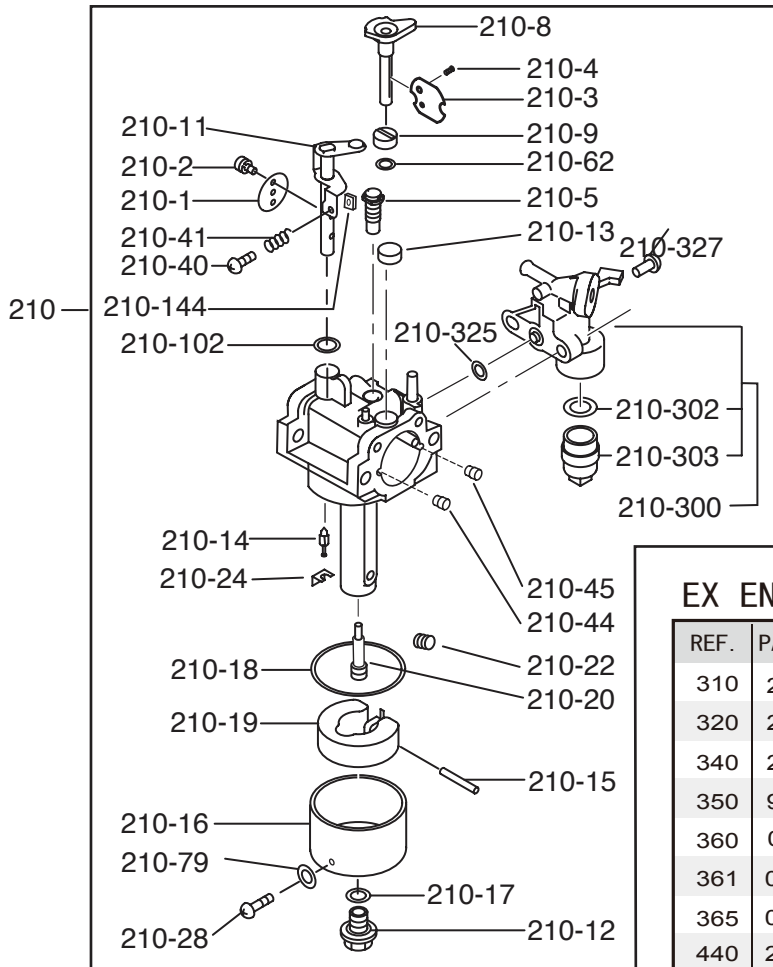

## EX ENGINE MUFFLER

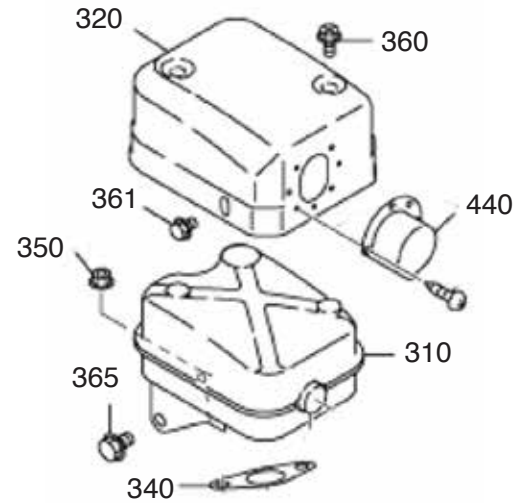

## EX ENGINE MUFFLER

税込

REF.	PART NUMBER	PART NAME	QTY	UNIT P
310	278-30101-01	MUFFLER CP	1	5,500
320	277-34201-31	MUFFLER COVER CP	1	2,000
340	277-35201-13	GASKET(MUFFLER)	1	140
350	980-20082-80	FLANGE NUT	2	160
360	015-20600-90	TAPPING BOLT	2	70
361	011-00600-50	FLANGE BOLT	1	80
365	011-00801-50	FLANGE BOLT	1	210
440	277-37001-03	DEFLECTOR	1	1,600

## 6 EX21 FUEL LUBRICANT

REF.	PART NUMBER	PART NAME	QTY	UNIT P
210	278-62302-30	CAB ASSY		8,400
210-1	277-62535-08	THROTTLE VALVE	1	920
- 2	209-62351-08	SCREW	2	70
- 3	277-62525-08	CHOKE VALVE	1	660
- 5	278-62420-08	PILOT JET #40	1	900
- 8	277-62520-08	CHOKE LEVER	1	1,300
- 11	277-62531-08	THROTTLE SHAFT-A	1	2,100
- 12	277-62451-18	BOLT	1	1,000
- 14	227-62500-08	NEEDLE VALVE	1	2,100
- 15	277-62515-08	PIN	1	200
- 16	277-62506-08	FLOAT BODY-A	1	2,500
- 17	214-62450-08	PACKING	1	80
- 18	214-62540-08	CHAMBER PACKING	1	280
- 19	226-62506-08	FLOT	1	1,820
- 20	278-62440-08	MAIN NOZZIE	1	1,600
- 22	277-62405-08	MAIN JET #83.8	1	920
- 24	226-62701-18	CLIP	1	330
- 28	277-62360-08	BOLT	1	470

REF.	PART NUMBER	PART NAME	QTY	UNIT P
- 40	106-62556-08	SCREW	1	80
- 41	283-62357-08	SPRIG	1	360
- 44	106-62411-08	MAIN AIR JET	1	870
- 45	106-62410-08	MAIN AIR PAILOT	1	870
- 62	236-62680-08	SEAL	1	310
- 79	236-62541-08	PACKING	1	280
-102	246-62390-08	SEAL	1	180
-144	277-62553-08	NUT	1	360
-300	279-62103-10	COCK BODY-A	1	1,100
-302	277-62110-18	PACKING	1	150
-303	277-62100-18	CUP	1	300
-325	277-62552-08	O-RING	1	330
-327	165-62377-08	SCREW	2	70
224	277-43801-01	CHOKE LFVER CP		360

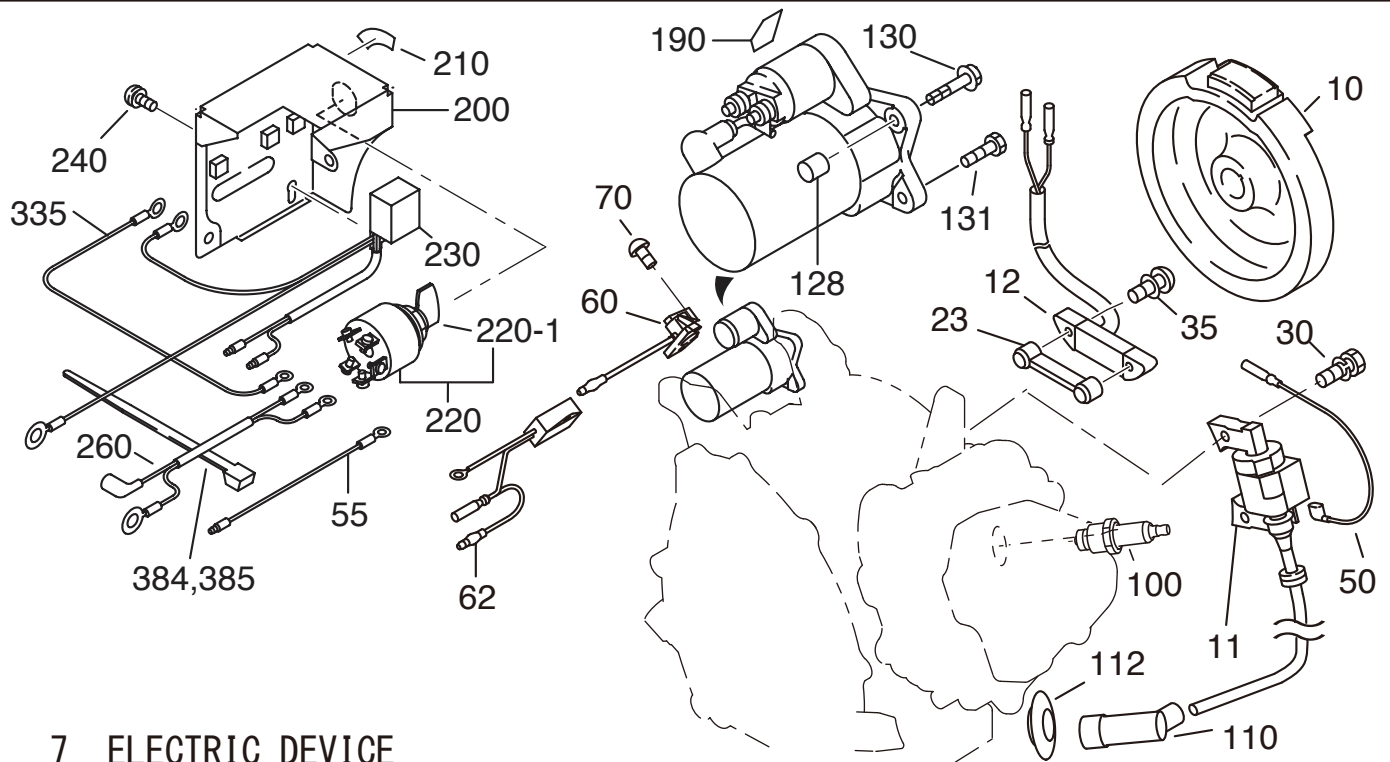

## 7 ELECTRIC DEVICE

REF.	PART NUMBER	PART NAME	QTY	REMARKS	CODE NO.	WEIGHT	UNIT P 税込
10	278-79274-01	FLYWHEEL CP	1	W/RING GEAR MF5368K	KX	2,600.0 g	23,100
	278-79271-01	FLYWHEEL CP	1	There is no starter gear type	KX	2,410.0 g	14,300
	278-79240-21	FLYWHEEL CP	1	There is no starter gear type	EX	2,400.0 g	12,000
11	277-79431-11	IGNITION COIL CP	1	MARK BM3803	EX/KX	197.8 g	6,710
12	277-79302-01	LAMP COIL CP	1		7527-	260.0 g	5,500
23	277-79501-03	SPACER	1		7527-	16.0 g	590
30	001-14062-50	BOLT AND WASHER AY	2	M6X1.OX25L W/W,SW		9.0 g	40
35	001-13064-00	BOLT AND WASHER AY	2	M6X1.OX40L SW		10.0 g	50
50	279-73105-H1	WIRE 5 CP	1	L=510 BLACK		14.0 g	730
55	277-73105-01	WIRE 5 CP	1	L=170 BLACK		3.7 g	260
60	066-00004-71	SWITCH AY	1	60mm	EX/KX	10.0 g	750
62	278-75601-10	SPEED LIMITER AY	1			56.4 g	19,500
100	065-01408-00	SPARK PLUG	1	NGK BR7HS(6HS/8HS)		8.0 g	580
110	065-50002-70	SPARK PLUG CAP	1			25.0 g	330
112	277-55201-03	GROMMET PLUG CAP	1			g	500
128	980-40081-10	STR PIN-8x10	1			1.0 g	90
130	011-00604-70	FLANGE BOLT	1	M6x1.0x13Dx20L		6.0 g	100
131	011-00604-80	FLANGE BOLT	1	M6x1.0x13Dx30L		8.0 g	100
190	073-20044-80	LABEL(BATTERY)	1			1.0 g	170
200	277-75101-01	CONTROL BOX CP	1			270.0 g	2,300
210	073-20044-60	LABEL(STARTER SWITCH)	1			g	220
220	066-00003-30	SWITCH	1			90.0 g	4,700
-1	066-00099-80	KEY SWITCH	2	MARK 103		10.0 g	970
230	277-71903-01	REGULATOR CP	1			71.1 g	6,600
240	011-00600-20	FLANGE BOLT	2	M6x1.0x14Dx12L		6.0 g	90
260	277-73103-11	WIRE 3 CP	1	L=230		14.0 g	600
335	277-73104-01	WIRE 4 CP	1	L=150 BLACK		4.0 g	240
384	056-30000-60	WIRE BAND	2	4.7Bx1.3Tx120L		0.8 g	190

## 7 ELECTRIC DEVICE

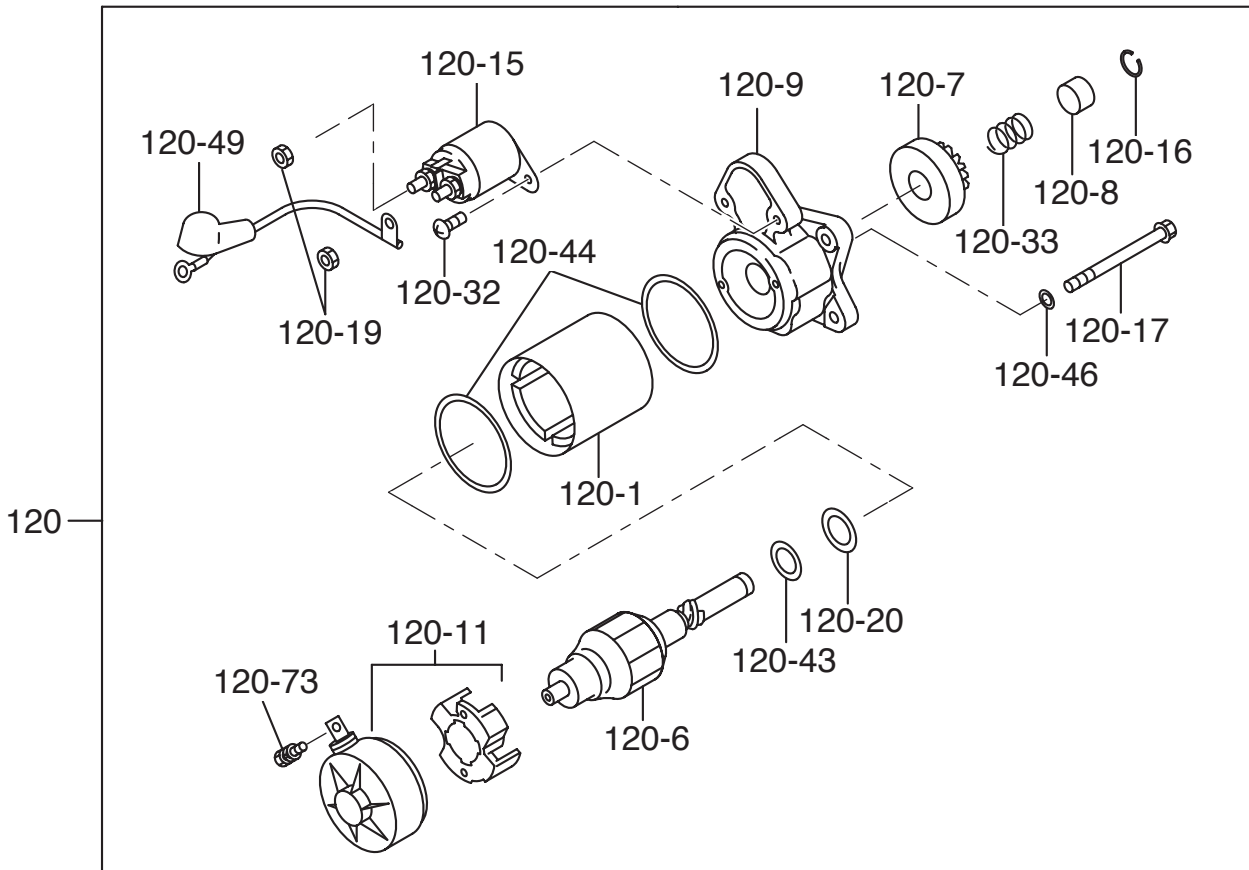

## 7 ELECTRIC DEVICE

REF.	PART NUMBER	PART NAME	QTY	CODE No.	WEIGHT	UNIT P 税込
120	277-70502-00	STARTING MOTOR AY	1		1,590.0 g	29,000
- 1	277-70550-08	YOKE ASSY	1	-	377.5 g	12,500
- 6	277-70551-08	ARMATURE ASSY	1	-	522.8 g	12,500
- 7	277-70520-08	CLUTCH SUB-ASSY	1	-	150.0 g	11,200
- 8	227-70561-08	NUT.PINION STOP	1	-	1.5 g	440
- 9	277-70501-08	HOUSING ASSY	1	-	210 g	5,200
- 11	277-70502-08	FLAME ASSY	1	-	126.0 g	2,100
- 15	277-70573-08	CONTACTOR ASSY	1	-	160.0 g	12,400
- 16	227-70562-08	RING. SNAP	1	-	1.0 g	110
- 17	277-70570-08	BOLT, THROUGH	2	-	9.2 g	220
- 19	254-70576-08	NUT	2	-	3.0 g	110
- 20	227-70573-08	WASHER PLATE SK	1	-	2.0 g	200
- 32	277-70574-08	SCREW.W/WASHER	2	-	g	110
- 33	277-70560-08	SPRING	1	-	g	280
- 43	227-70574-08	COLLAR. ARMATURE	1	-	13.0 g	730
- 44	227-70572-08	O-RING	2	-	g	210
- 46	277-70571-08	O-RING	2	-	2.5 g	300
- 49	277-70572-08	WIRE, SUB-ASSY	1	-	16.6 g	660
- 73	227-70577-08	BOLT, W/ WASHER	1	-	g	130

