

# EX21 ⇒ KX21 変更部品

## Changed from EX to KX

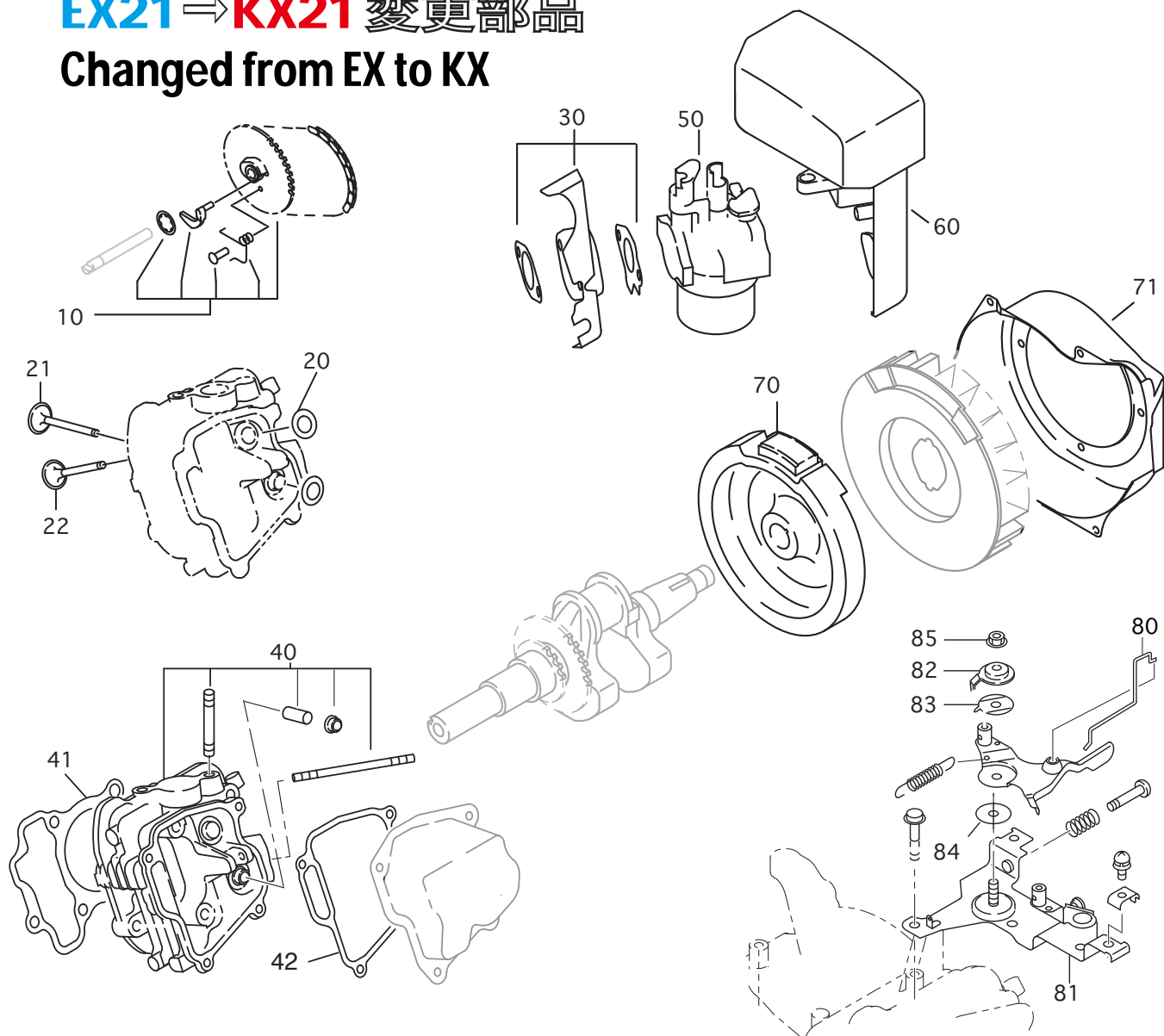

REF.	PART NUMBER	PART NAME	QTY	REMARKS		
10	278-31602-01	CAM SHAFT CP	1	85DX2.9B N=40		6,000
20	278-38802-03	SPACER SPRING	2		@95×2枚	200
21	279-33401-H3	INTAKE VALVE	1	28.5DX5.5DX67.8L		1,050
22	279-33501-H3	EXHAUST VALVE	1	26.5DX5.5DX67.8L		1,700
30	279-32905-H0	INSULATOR AY	1			1,000
40	278-13010-01	CYLINDER HEAD CP	1			10,000
41	277-15001-23	GASKET(HEAD)	1	T=0.2		500
42	277-16001-13	GASKET(ROCKER COVER)	1	T=0.5		230
50	278-62351-00	CARBURETOR AY	1			8,600
60	279-32615-60	AIR CLEANER AY	1			6,800
70	278-79271-01	FLYWHEEL CP/FLYWHEEL	1	Electric starter非対応		14,000
71	278-51282-01	BLOWER HOUSING AY	1			3,800
80	277-42703-11	DIRECT ROD CP	1			330
81	277-46002-02	SPEED CONT.BRKT.UN	1			600
82	277-43502-03	STOP PALET	1			240
83	277-44501-03	WASHER	1			60
84	021-70600-70	FRICTION WASHER	1	6.5DX24DXO.8T NYLON		50
85	002-35060-00	SELF LOCK NUT	1	M6X1.0X6.8H		80
					パーツ合計	55,240

※組み替えの工賃は別途費用が掛かります。  
 ※リコイルスターターから電動スターターへの変更は別途費用が掛かります